

“PRACTICAL MARINE APPLICATIONS OF RENEWABLE METHANOL”

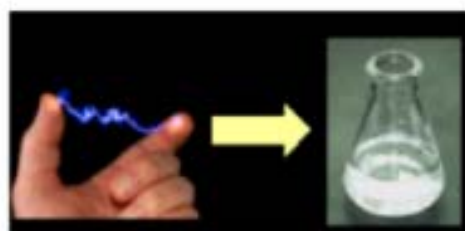

Paul Wuebben

Senior Director, Renewable Fuels

CARBON RECYCLING INTERNATIONAL

**Symposium on Evolution of Maritime Fuels,
Ship Speed and Operational Efficiency**

USC Sea Grant Program

Loker HC Research Institute, July 21, 2014



Carbon Recycling International

OUTLINE

- ▶ ENERGY AND REGULATORY CONTEXT
- ▶ SUSTAINABLE METHANOL
 - ▶ *CRI'S CO₂ TO METHANOL PLANT*
- ▶ METHANOL SHIP DEMONSTRATIONS
- ▶ METHANOL OUTLOOK
- ▶ CONCLUSIONS



BEWARE OF ENERGY COMPLACENCY:

- ▶ For 70% of the world's oil fields, according to the IEA, the rates of decline of these fields is now observed at 6.2%/yr.
- ▶ Since the year 2000, global upstream CAPEX grew 3 x from \$250 B to \$700 while total supply grew by only 12%.
- ▶ While No. America now accounts for 20% of the world's oil production, it accounts for 50% of the world's CAPEX for oil.
- ▶ 2013 global energy demand reached another all time peak
- ▶ Even if the US becomes "energy self-sufficient" for the next decade, it will remain coupled to the global price of crude oil.
- ▶ Exxon Mobil has removed staff from two large fields in the south of Iraq.
- ▶ Russia: oil and NG wildcard / supply insecurities
- ▶ Middle East volatility is escalating (Syria, Iran, Iraq, etc.)
- ▶ Unabated global demographics



Marine Fuel Innovation Driver:

- Regulations driving change
- Emission Control Areas (ECA) 2015 near term focus
- In 2020, IMO targeting all marine fuels globally to be 0.5% sulphur

MEPC 57 IMO Fuel-sulphur Content
Equivalent methods may be used as alternative

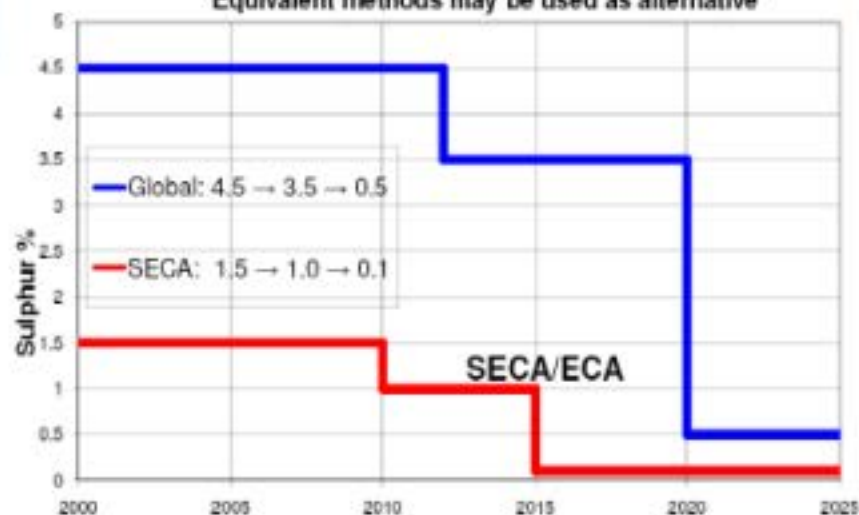

Global Emission Control Areas (ECA's)



Methanol and LNG, two sides of the same coin



Natural Gas (Methane)



$\eta=70\%$

$\eta=90\%$

Methanol

LNG



Cheap Distribution

Expensive Distribution



Renewable Methanol possible

→ \$?



LNG CONCERNS

- ▶ Boil-off
- ▶ Pressure Increases
- ▶ Methane Slip
- ▶ Future regulations on fuel tank proximity to crew quarters



**“George Olah CO₂ to Renewable Methanol Plant” Groundbreaking
HS Orka Svartsengi Geothermal Power Plant, Iceland, October 17th 2009**



Emissions to Liquids Production Process

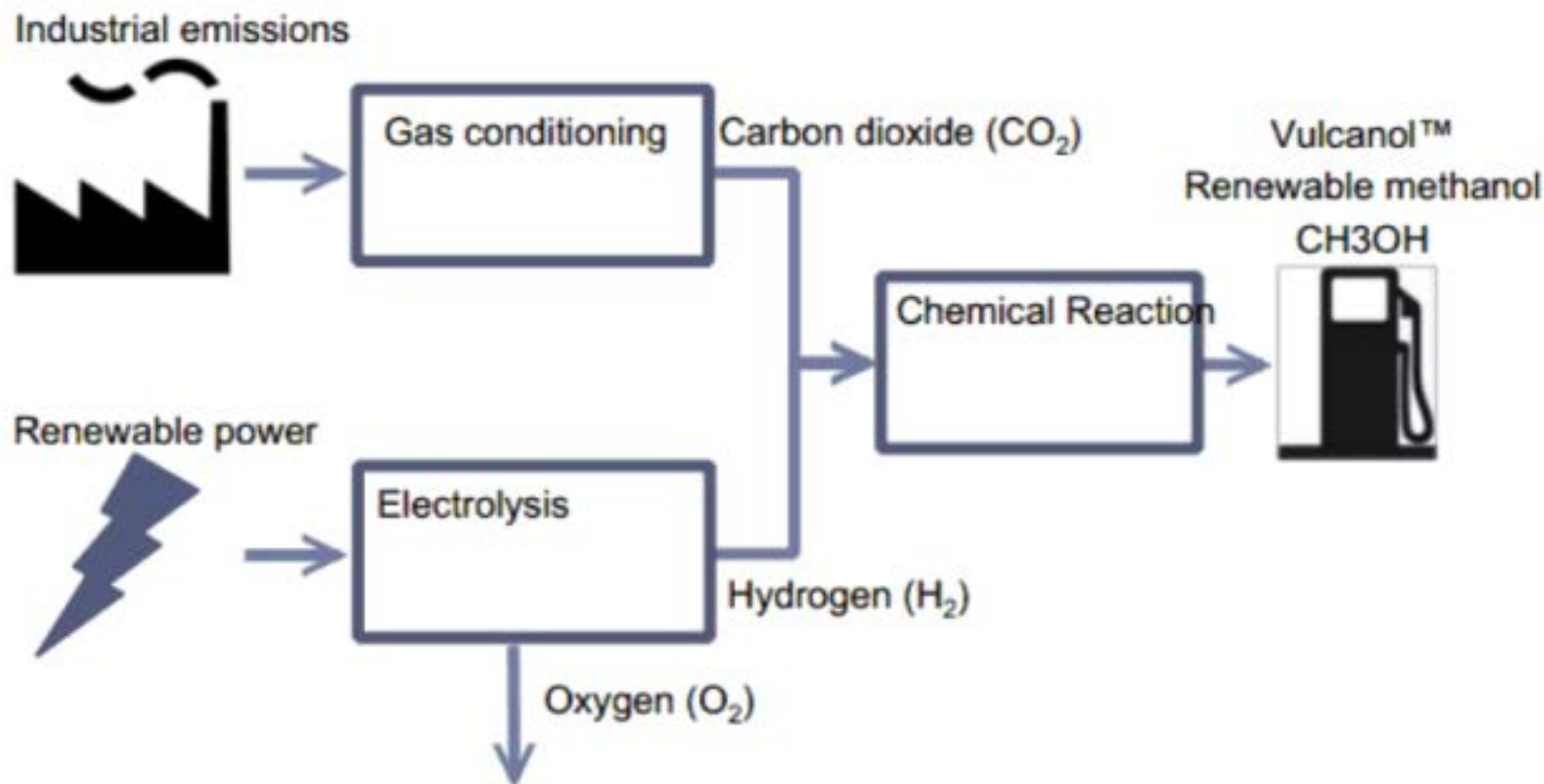



Carbon Recycling International



Carbon Recycling International



1.7 Million L / yr
2 MWe

Now (Phase I)

1,800 t/yr CO₂

1,300 t/yr methanol

Gas Conditioning



**Chemical
Reaction**

Expanded capacity (Phase II)

5,500 t/yr CO₂

4,000 t/yr methanol

5 Million L / yr

5 MWe

Distillation

CO₂

Hydrogen (H₂)



Industrial scale plant in operation from 2012



Carbon Recycling International

Diversity of Renewable Energy Sources:

Renewable Energy



Recycled emissions



Renewable products

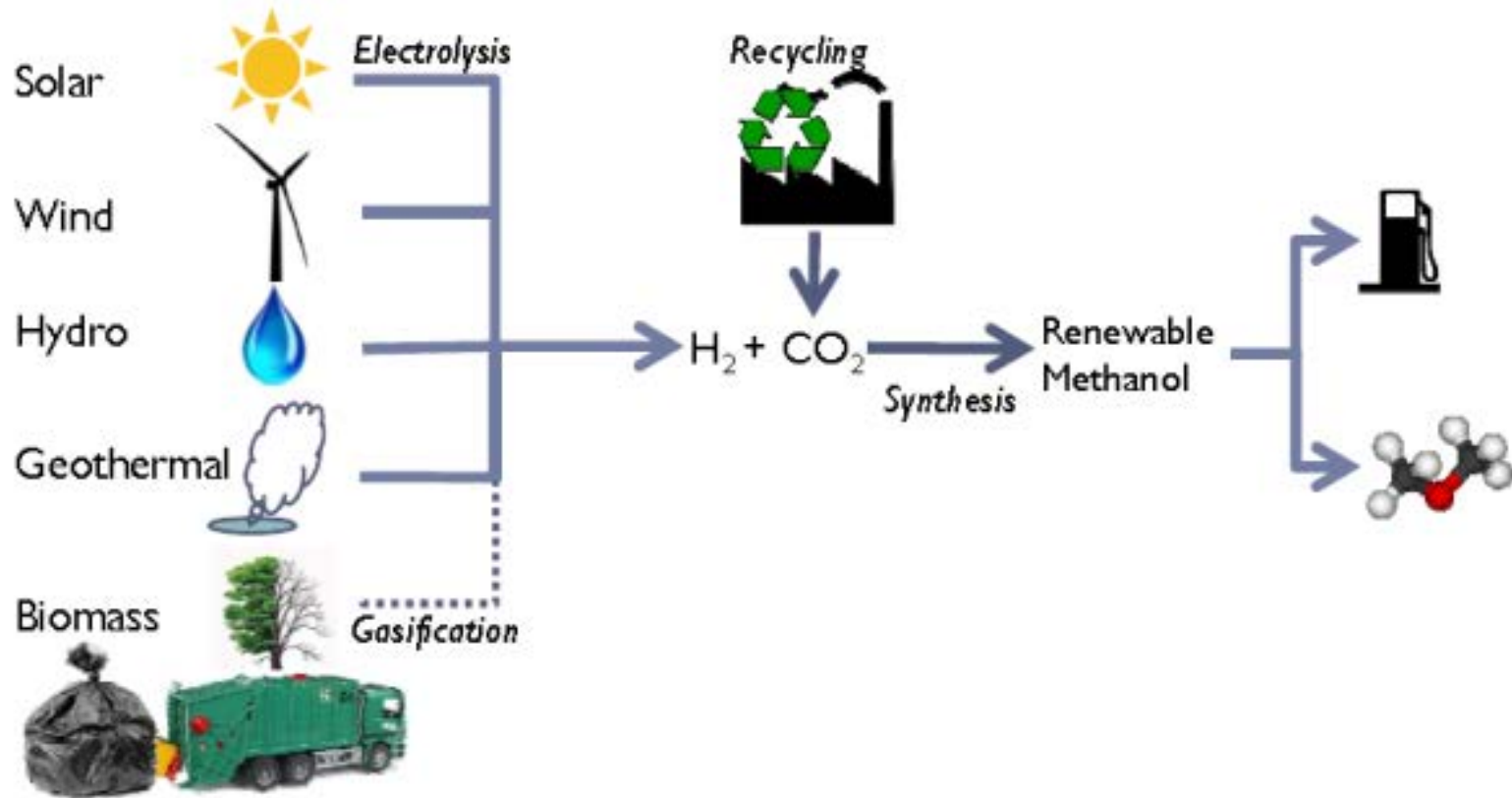

Carbon Recycling International



Efficiency of Alkaline Hydrogen Electrolysis



State of the art

Specific energy consumption (W): 3,7 – 4,8 kWh/Nm³ H₂

→ Efficiency: 63 – 80% (based on the LHV)

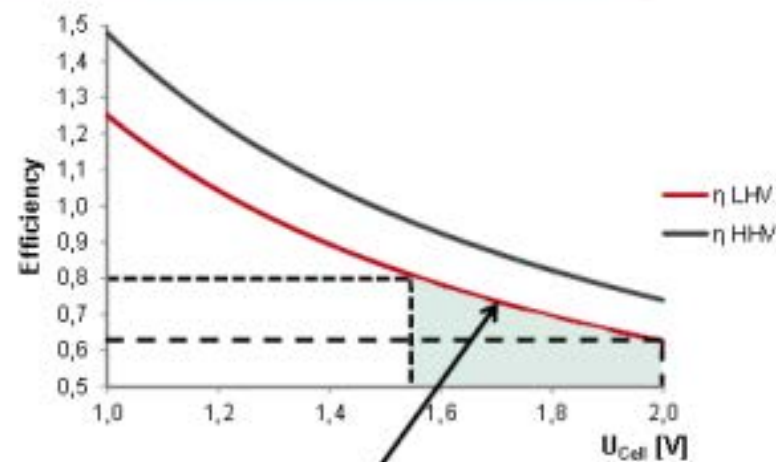
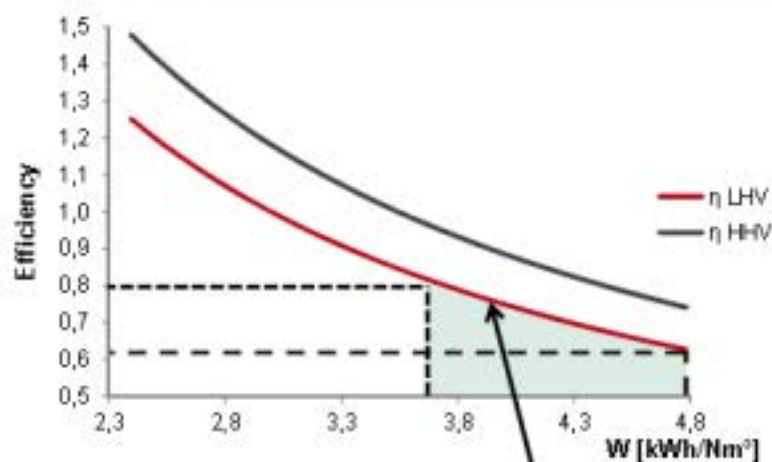

Specific energy consumption: 4 kWh/Nm³
Cell voltage: 1,7 V (Assumption for industrial use)
Efficiency (LHV): 74%



And Diversity of CO₂ Sources

Renewable Energy + Recycled CO₂ Emissions → Renewable Products

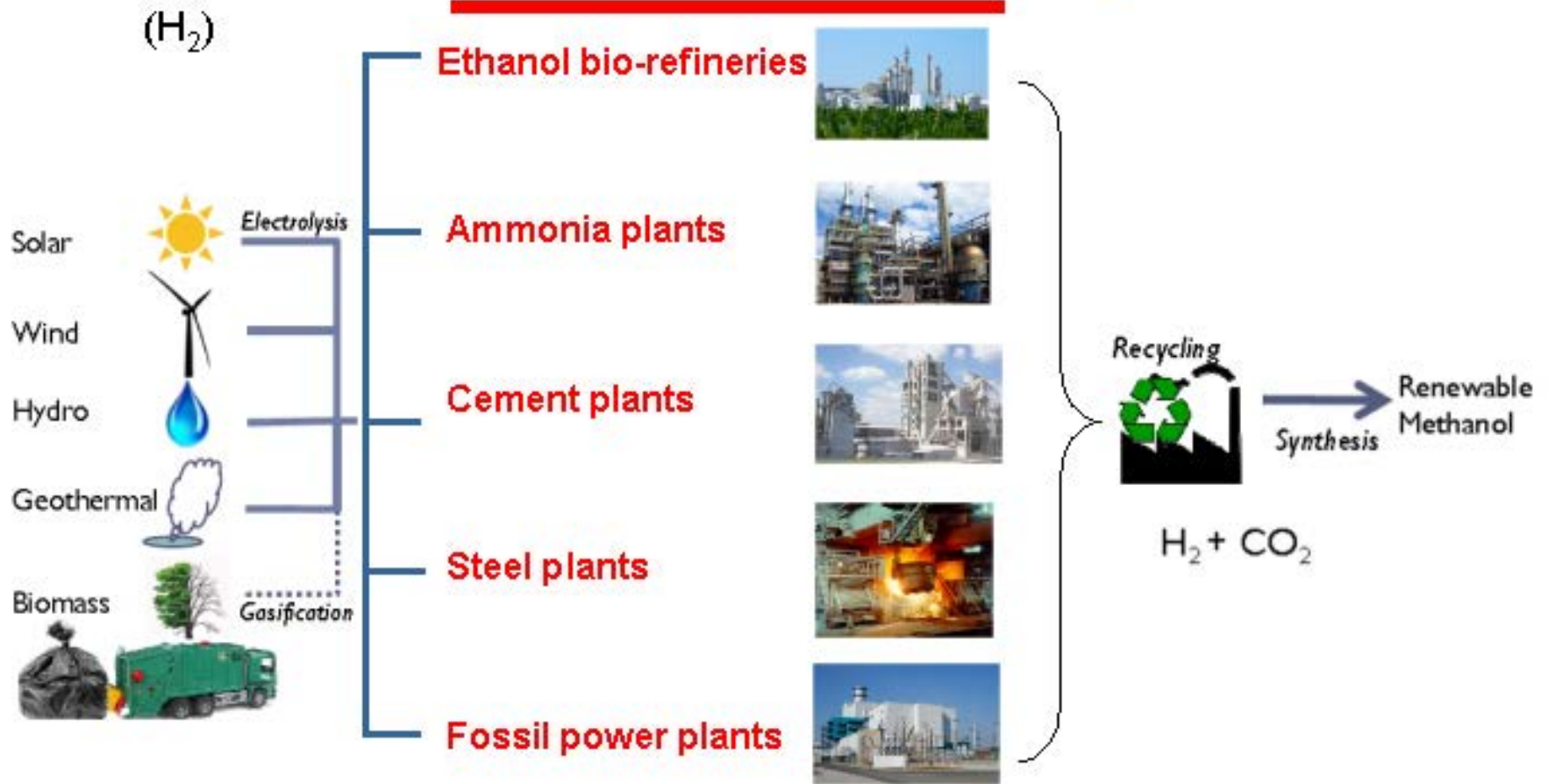

Carbon Recycling International

Growing Consumers

 **Perstorp**
WINNING FORMULAS



Carbon Recycling International

The Renewable Methanol achieves GHG savings of 90,4 %. Compared to existing alternative options this is a very positive result*

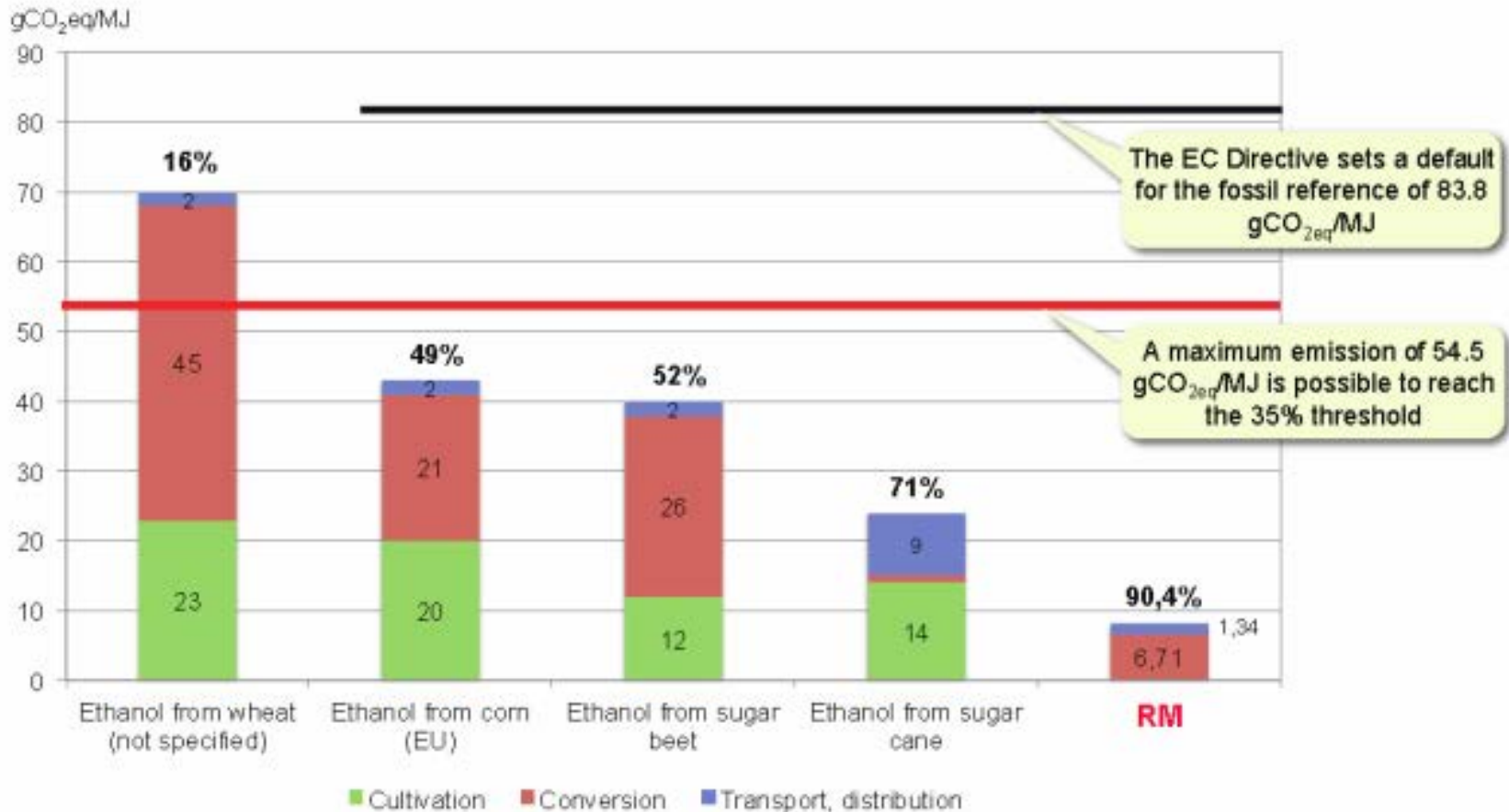

* Based on biofuels default factors from RED



- ▶ **First** in building an industrial plant to commercialize power to liquid fuel
- ▶ **First** in utilizing kilotons of per year of CO₂ to make liquid fuel
- ▶ **First** in operating multi-megawatt electrolyzers for power to liquid fuel
- ▶ **First** in producing kilotons per year of renewable methanol for gasoline blending and biofuel manufacturing
- ▶ **First** in holding an International Sustainability and Carbon Certification for a renewable fuel with 90% reduction of CO₂ compared to gasoline



THE TRANSITION TO RENEWABLE METHANOL:

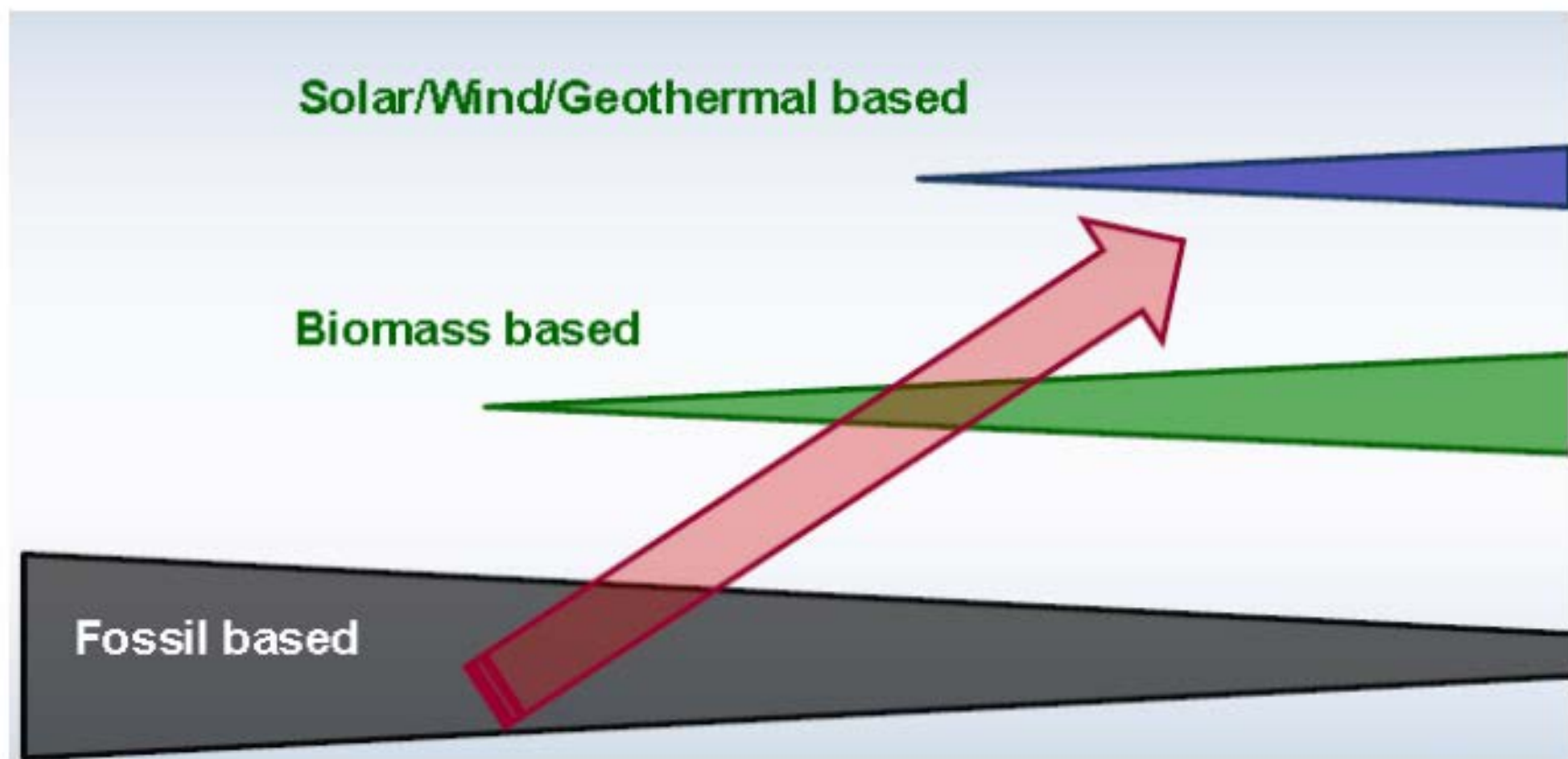

Limitless Potential for Renewable Power to Methanol Fuel

Power Consumption
Today:

17 TW

Potential

TW

Hydroelectric

1

Biomass

7

Geothermal

6

Wind

8

Solar

488

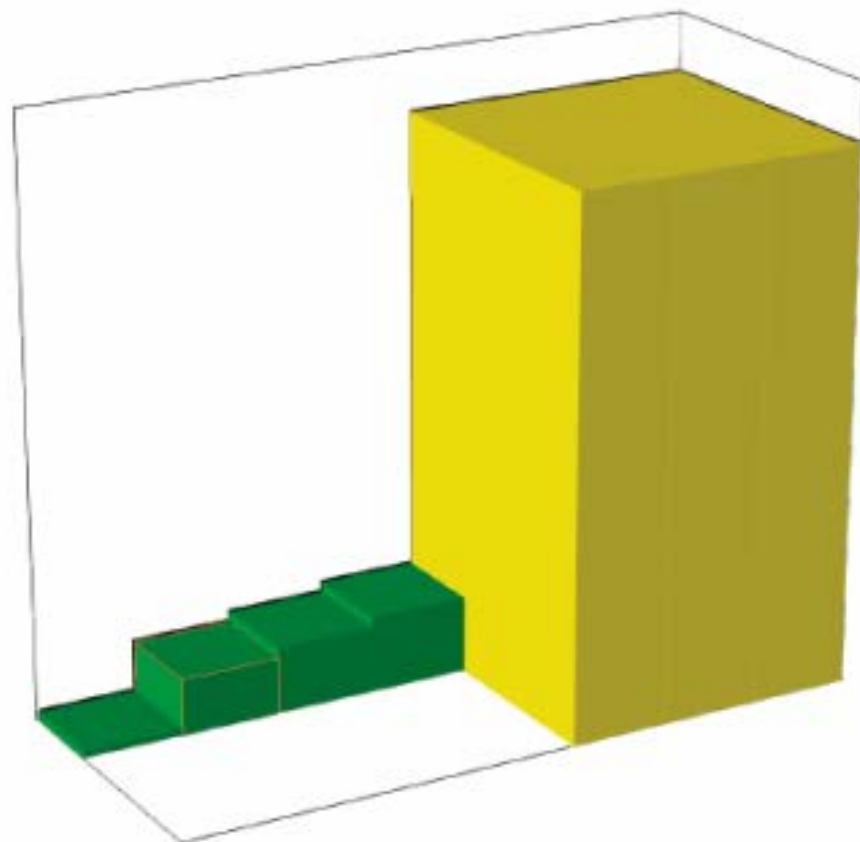

CURRENT METHANOL USES

- Methanol is being used in an increasing number of energy applications

Traditional Uses (60% of Demand)

Formaldehyde

Wood Industry, Pharmaceuticals, Automotive



Acetic Acid

Fleece, Adhesives, Paints



Dimethyl Terephthalate

Recyclable plastic bottles



Methyl Chloride

Silicones



Energy & MTO (40% of Demand; High Growth)



Fuel Blending



DME (di-methyl-ether)

MTO

Methanol-to-Olefins

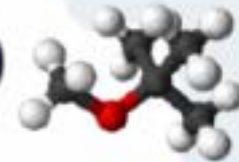

MTBE



BIO DIESEL



Marine Fuels



Methanol Characteristics

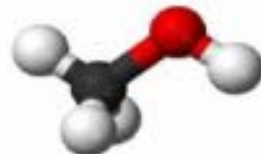

<u>Fuel</u>	<u>Methanol</u>	<u>Natural Gas</u>	<u>Diesel</u>
Density (kg/l)*	0.79	0,44 (as LNG)	0,85
Boiling point (°C)	65	-162	150- 370
Flash point (°C)	11	-188	min. 60
Auto ignition (°C)	464	540	240
→ Viscosity cSt at 20°C	~ 0,6	na	~ 13,5
Octane RON/MON	109/89	120/120	-
→ Cetane No.	3	-	45-55
→ LHV (MJ/kg)	20	50*	42
Flammability Limits, Vol%	7- 36	5- 15	1- 6
Flame Speed (cm/s)	52	37	37
Heat of Evaporation (kJ/kg)	1178	na	233
Stoichiometric Air- Fuel Ratio	6,45	17,2	14,7
Adiabatic flame temp. (°C)	1910	1950	2100



The DRAFT INTERNATIONAL CODE OF SAFETY
FOR SHIPS USING GASES OR OTHER LOW FLASH
POINT FUELS (IGF CODE). **Under development.**

Intended fuels:

- **Natural Gas (LNG)** **CH₄** IGF Code Part A-1
- Propane C₃H₈
- Butane (i and n) C₄H₁₀
- Propane/Butane mixtures
- Ethyl alcohol C₂H₅OH IGF Code Part A-2
- **Methyl alcohol** **CH₃OH** IGF Code Part A-2
- Hydrogen H₂
- Dimethyl-ether CH₃OCH₃



METHANOL MARINE DEMONSTRATIONS:

- ▶ **Methanex tankers**
 - ▶ MAN engines
- ▶ **Spireth** (methanol + DME)
 - ▶ MAN + Wartsila
- ▶ **Stena Germanica** (methanol conversion)
 - ▶ Wartsila
- ▶ **Wartsila** methanol / diesel
 - ▶ Engine testing + development



Methanol Marine Engine OEMs:

WÄRTSILÄ & MAN

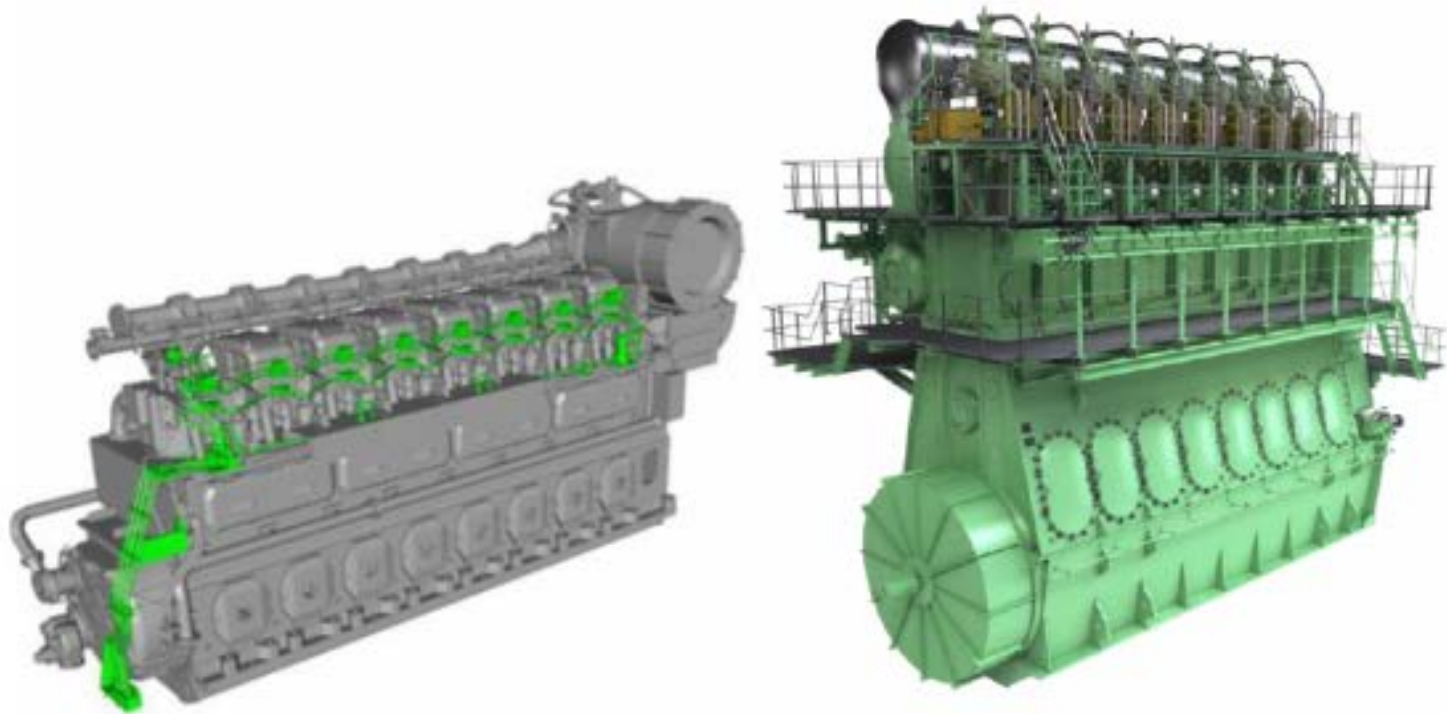

Carbon Recycling International

Methanex: 7 Tankers to be Powered by Methanol

Mitsui O.S.K Lines Ltd.

World's first methanol-driven carriers



Order details	
No. of ships	3
No. of engines	3
Ship type	Methanol carrier
Capacity	50 000 dwt
Engine type	7500MC-B9.3-LGI
Builder	VWS
Year	2010
Engine delivery year	2010
Main fuel	HFO, MGO, Methanol

WATERFRONT



Shipping Company Limited
A Responsible Care® Company

MAN S50ME-B9.3-LGI

Two stroke high pressure gas (methanol) engine

7 x 50 000 dwt Chemical Tankers on order.



Carbon Recycling International

- SPIRETH Project - technology confirmation
- Engine manufacturers developing methanol compatible engines
 - MAN - 2 stroke engines
 - Wartsila - 4 stroke engines
- Standards and regulations under development
 - Risk Classification Societies - DNV, Lloyd's Register
 - Marine fuels regulations being updated for methanol



SPIRETH

- Bunker methanol CH_3OH
- Upgrade methanol to DME (CH_3OCH_3) onboard
- Use the DME in the existing diesel engines (only minor modifications required)



SPIRETH

- The benefits
 - Methanol/DME is available everywhere and limited only by the amount of feedstock (gas, coal, biomass etc)
 - The methanol market like gasoline is more transparent than LNG market
 - Methanol can be stored in hull tanks
 - Methanol/DME energy cost lower than for Marine Gas Oil
 - Methanol-DME operation will fulfil tier 3 NOx requirements without after treatment
 - Cost for conversion and/or adaption to methanol is a fraction of the comparable cost for LNG



Summary - Stena Germanica Methanol Conversion

- ❑ Complementary *retrofit* solution to reach Sulphur level of 0,1%
- ❑ Based on adapted known technology
- ❑ Minor modifications on engine (Common Rail addition)
- ❑ Dual fuel capacity, full redundancy - Methanol / Diesel
- ❑ No reduction in efficiency running on methanol



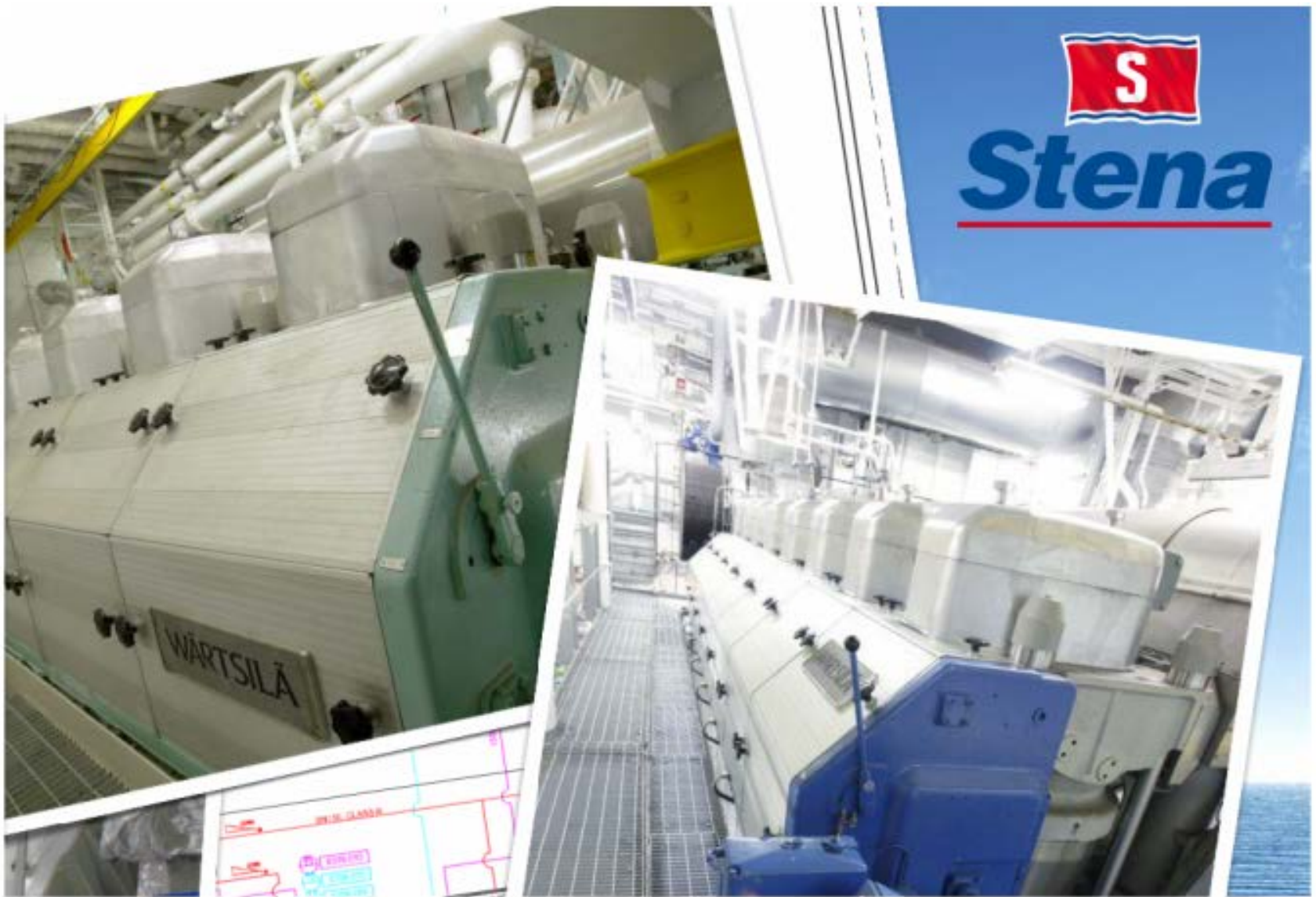

Carbon Recycling International

Source: [4_Stena-Per_Stefenson20140508.pdf](#)



Carbon Recycling International

Source: [4_Stena-Per_Stefenson20140508.pdf](#)

Methanol

Conversion cost; 300 Euro/kW

Comparable with Scrubber



Source: [4_Stena-Per_Stefenson20140508.pdf](#)



Carbon Recycling International

METHANOL RELATED MODIFICATIONS: STENA GERMINICA

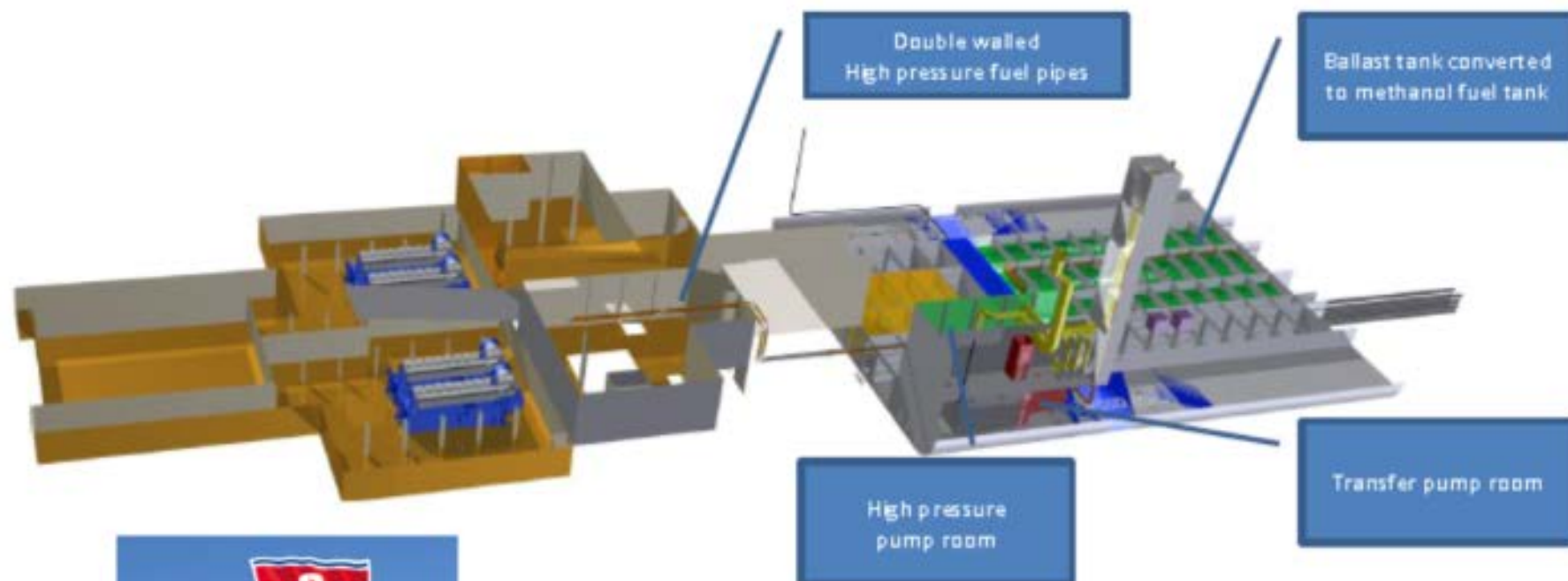

WARTSILA METHANOL ENGINE OPTIONS:

Use of Methanol in Internal Combustion Engines

Diesel Engine Concept for OBATE-DME *

The traditional HFO, or LFO, is replaced with OBATE-DME in a diesel engine. Since OBATE-DME is a gas at atmospheric pressure you need to pressurize the fuel supplyand return system. The challenge is the major modifications of the fuel injection system to handle fuel characteristics: As low viscosity, low heat value, low cetane number and high compressibility. Full output achievable.

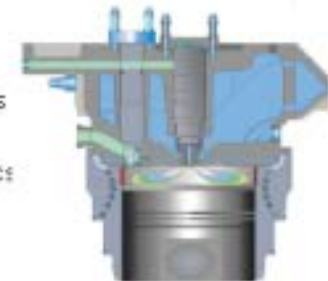

Duel Fuel concept for Methanol

In this concept you replace the gas valve on a DF-engine, or complete the engine, with a methanol injector. You ignite the compressed premixed methanol-air mixture with a small pilot fuel diesel spray when the piston is close to TDC. Performance corresponding to the DF concept.



Methanol-Diesel concept for Methanol

You inject the methanol at high pressure close to TDC and ignite with pilot diesel. By using the diesel principle you avoid knocking problems, which you might face using the methanol in a Duel Fuel engine. Area for adaption is the fuel injection system for the methanol. Full output achievable.

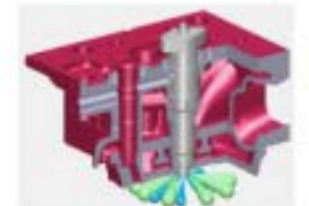

* *On-line conversion of MeOH to DME/MeOH/water mix*



Wärtsilä Methanol-Diesel retrofit solution

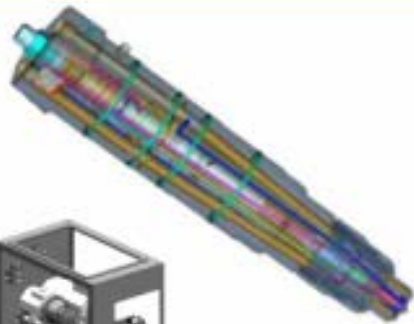

On-engine scope is limited to **exchange of cylinder heads, fuel injectors and fuel plungers** in existing fuel pumps. A **common rail system** for methanol injection will be added on the engine.

In addition to the Engine related conversion includes the conversion kit a **stand-alone high pressure methanol pump with belonging oil unit** for supply of sealing oil and control oil to the fuel injectors.

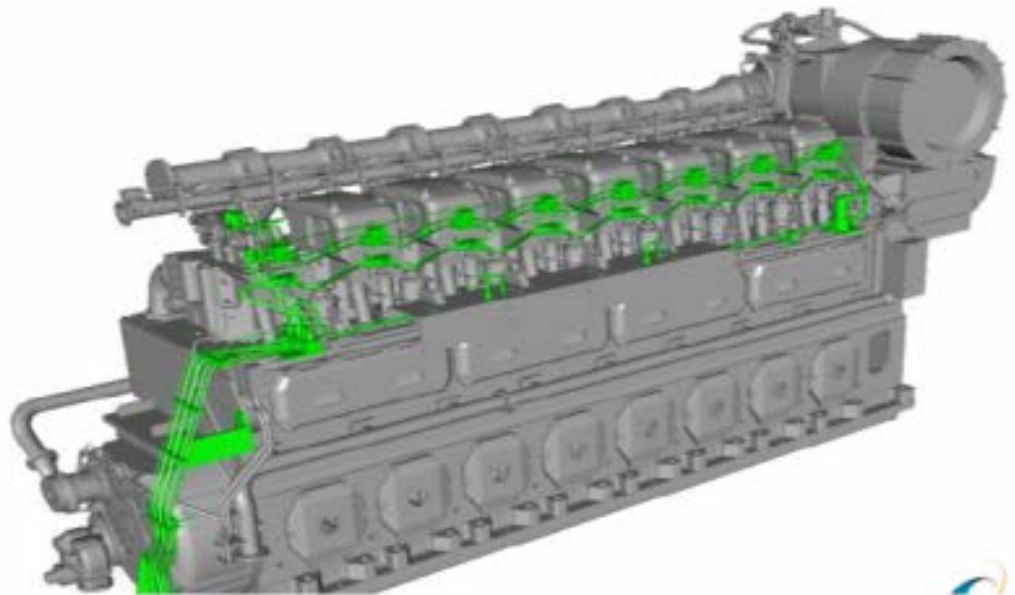

Wärtsilä Methanol-Diesel retrofit concept

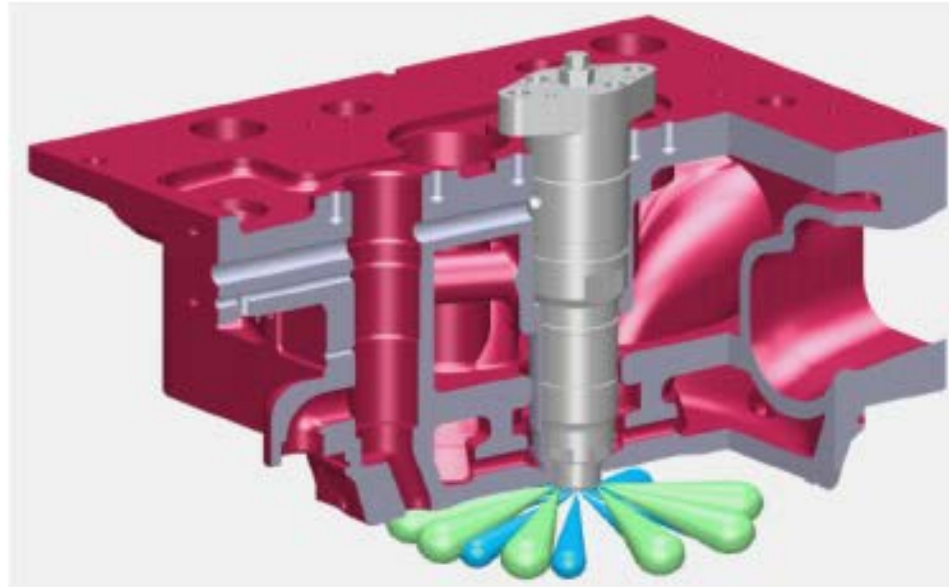

Methanol is combusted according to the diesel process. The methanol is injected close to TDC and ignited by a small amount of pilot fuel - in this case traditional diesel fuel.



Methanol-Diesel Concept

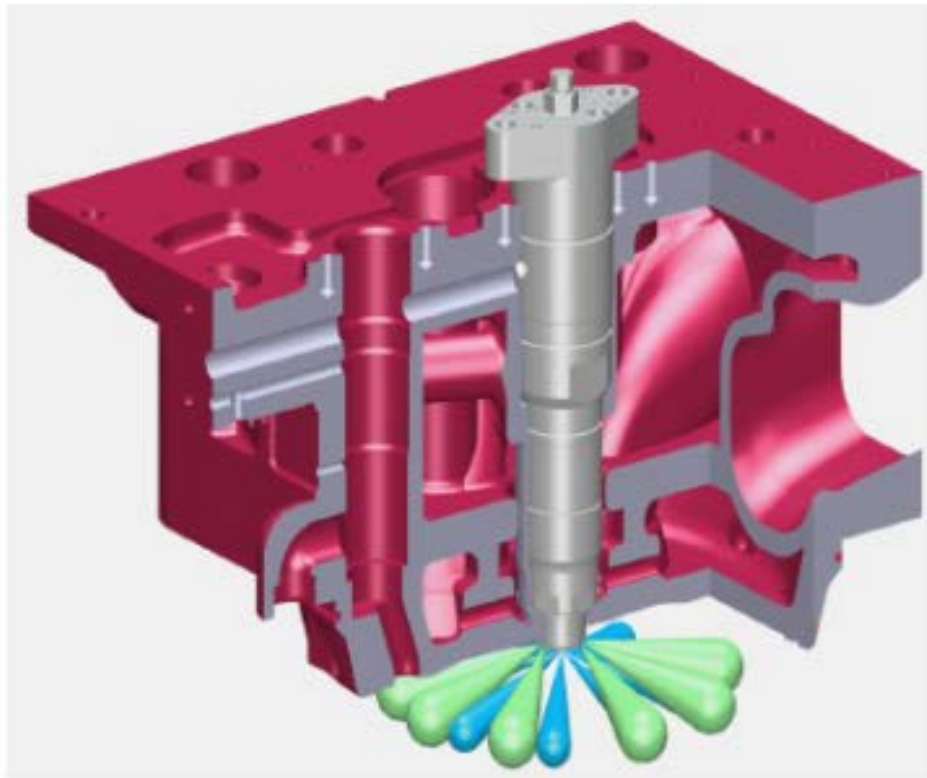

- + no knocking (diesel combustion)
 - + no power reduction**
 - + good load acceptance
 - + cost effective adaption**
 - + low THC, CO and formaldehyde levels
 - + good back-up fuel performance
 - + HFO pilot fuel possible
-
- **NOx higher than for DF concept**^{*}
 - depending on pilot fuel for ignition

*** DF = Dual Fuel**



Carbon Recycling International

WARTSILA

METHANOL- DIESEL TEST RESULTS

- NOx acceptable (Low Tier II values)
- CO acceptable (< 1 g/kWh)
- THC acceptable (< 1 g/kWh) and no “methane slip”
- Very low PM (FSN ~ 0,1 with HFO as pilot)
- Formaldehyde emissions low 15-20 ppm (below TA-luft limit)
- Efficiency with methanol comparable to diesel
- No Formic acid detected in exhaust **gases**



FUEL INJECTION: *The Heart of the Solution*

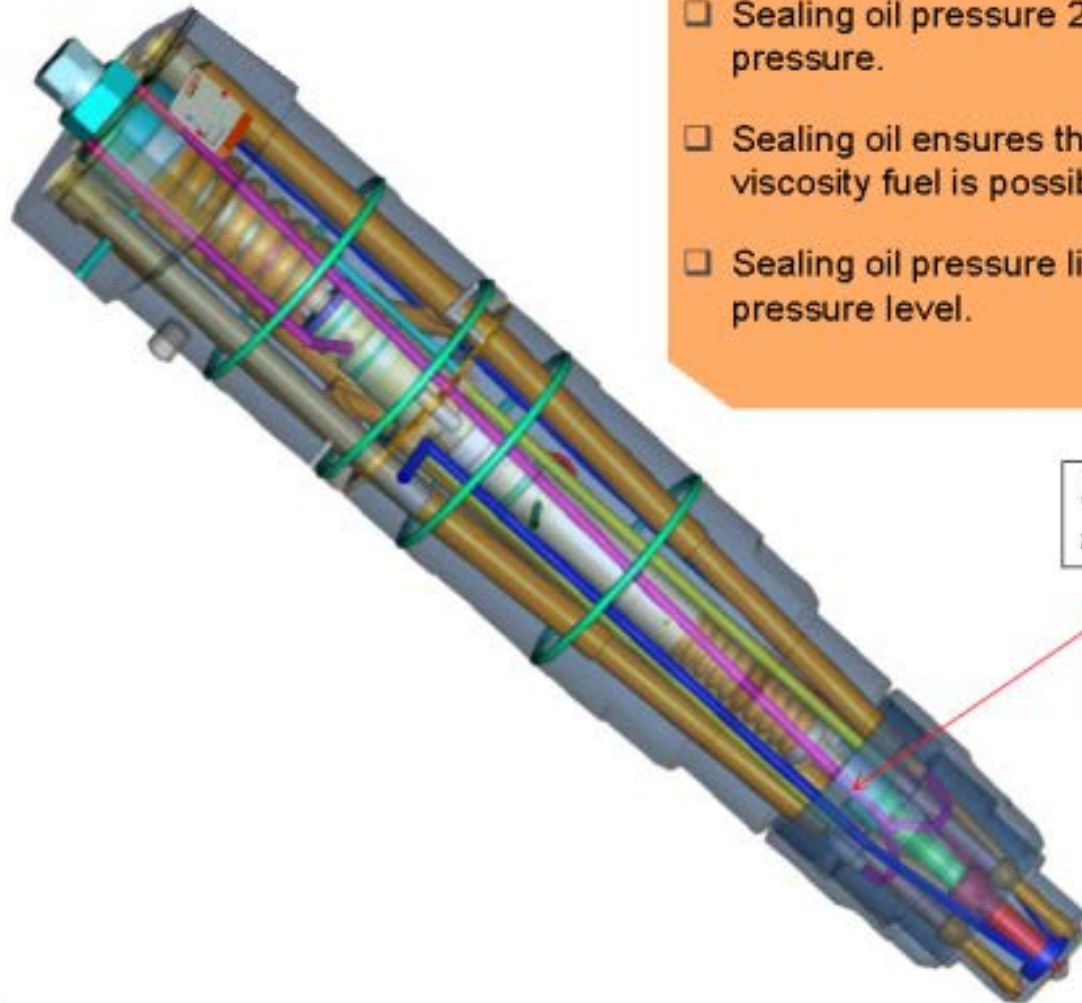

- ❑ Sealing oil pressure 20bar over gas pressure.
- ❑ Sealing oil ensures that use of low viscosity fuel is possible.
- ❑ Sealing oil pressure limits the injection pressure level.

Sealing oil
around needle



WARTSILA METHANOL MARINE ENGINE TEST RESULTS

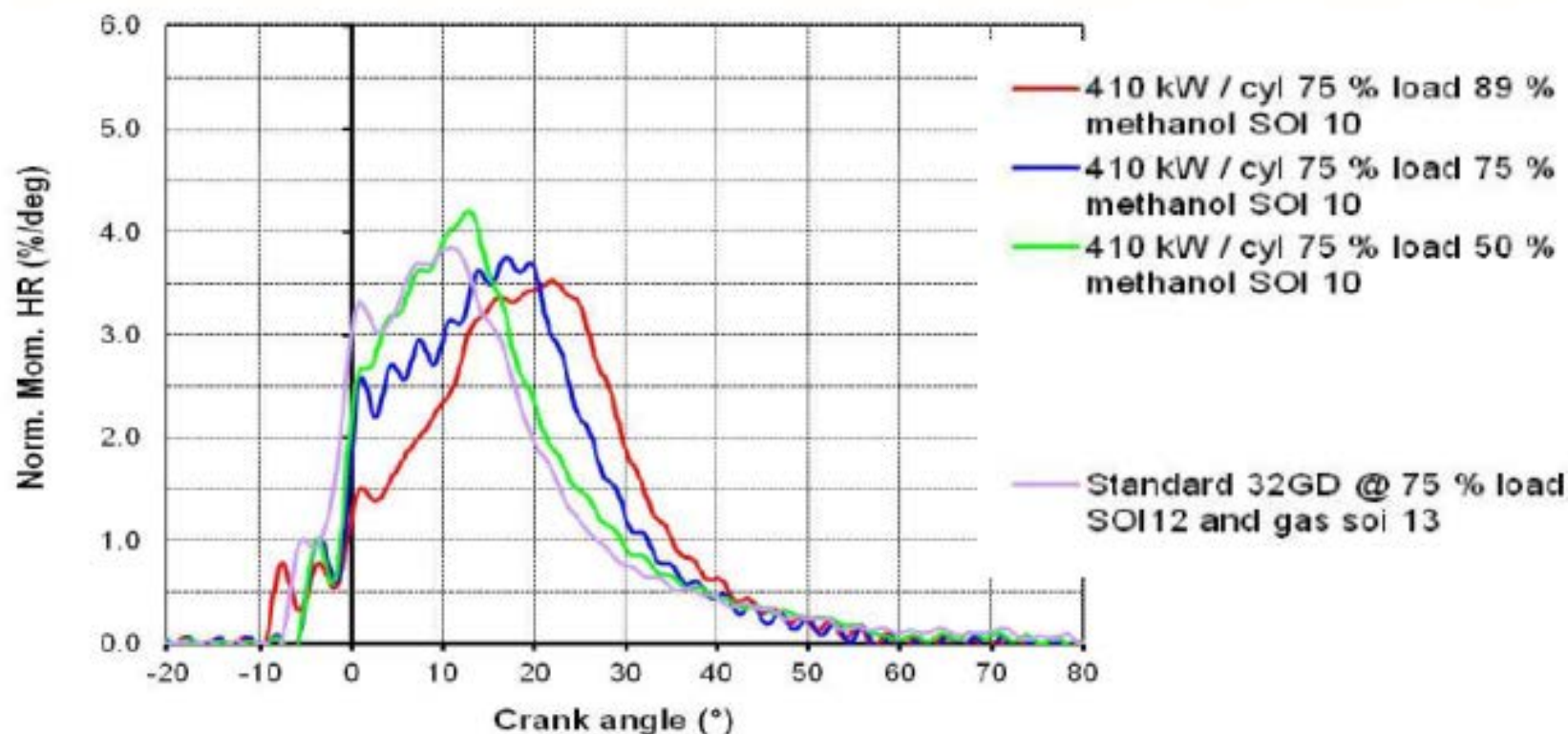

Optimal heat release



Carbon Recycling International

Source: Wartsila, Promsus Workshop,
Gothenberg, Sweden - May 6, 2014

WARTSILA METHANOL MARINE ENGINE TEST RESULTS

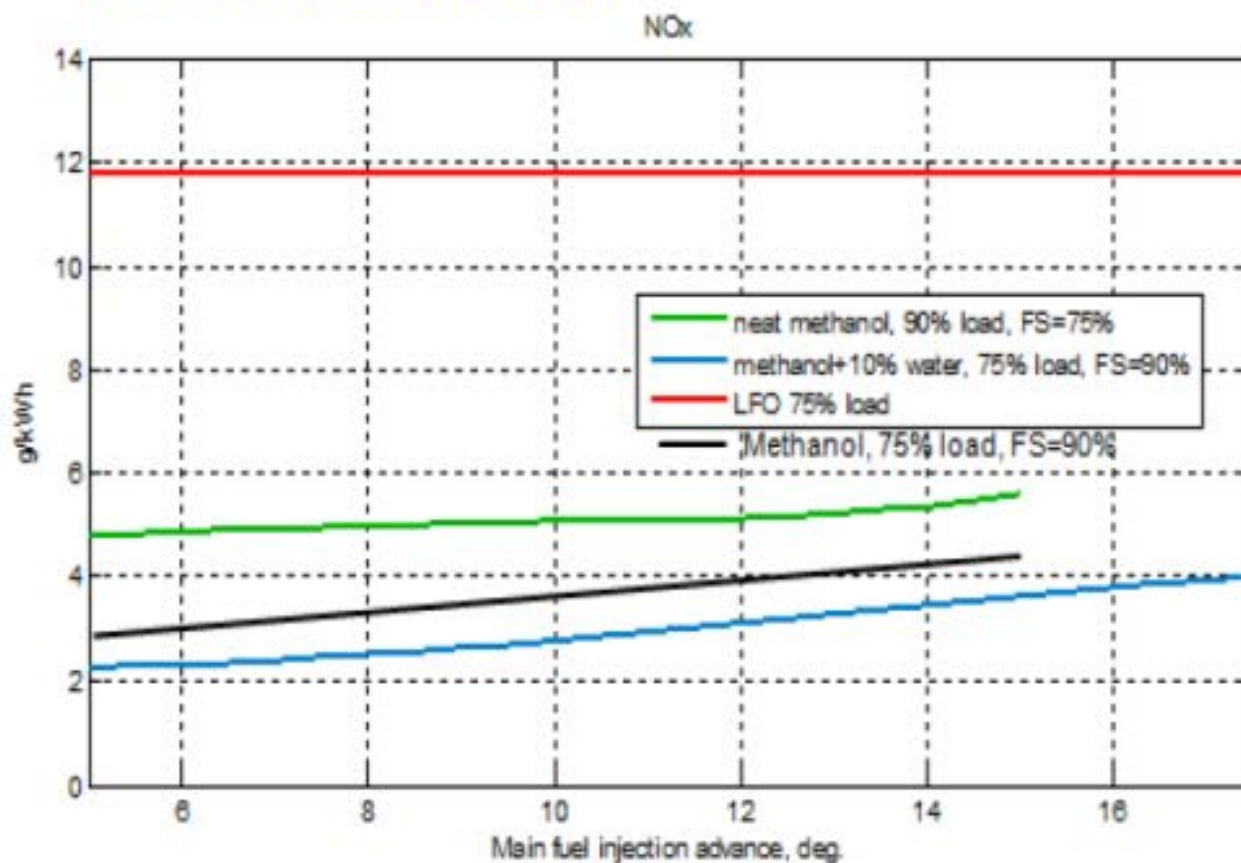

Reduced NOx (-70%)

Source: Wartsila, Promsus Workshop,
Gothenberg, Sweden - May 6, 2014



Carbon Recycling International

WARTSILA METHANOL MARINE ENGINE TEST RESULTS

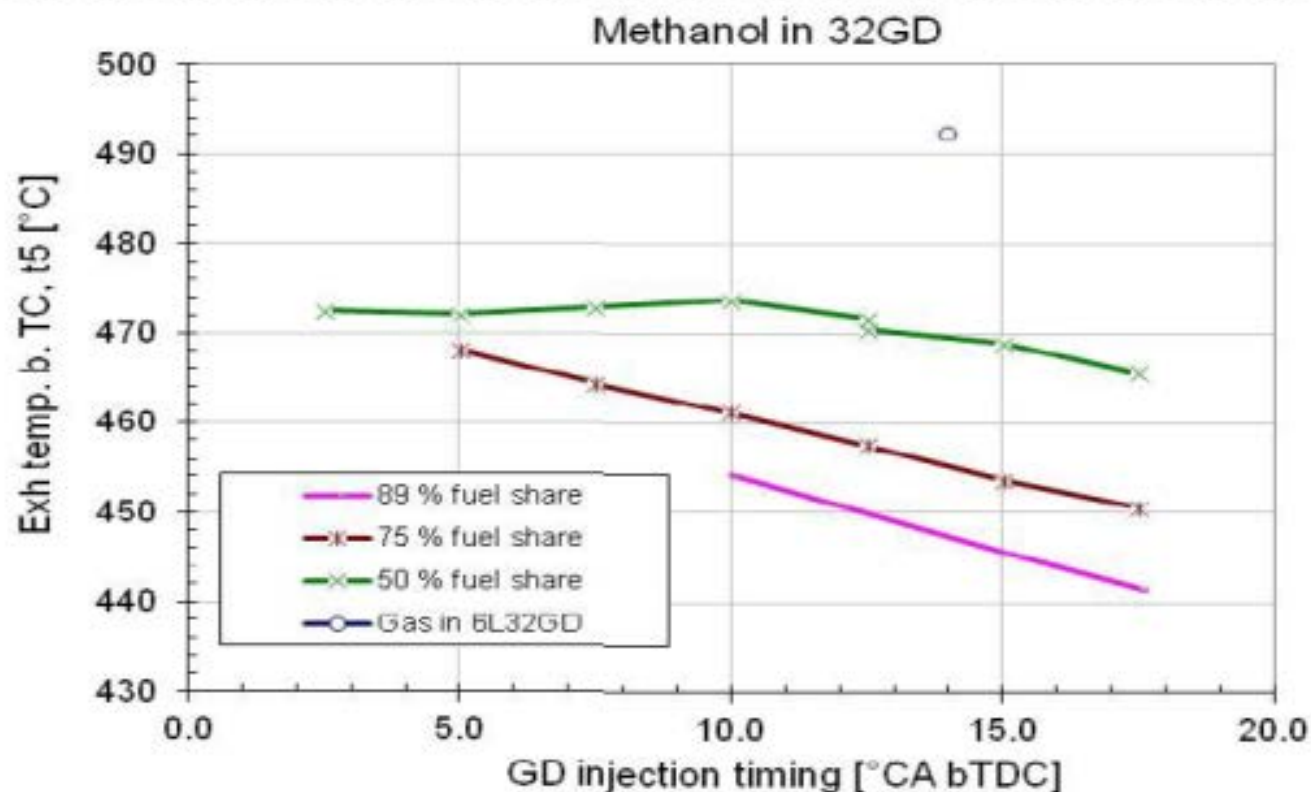

**Lower Exhaust Temperature
(up to 50 C)**



WARTSILA METHANOL MARINE ENGINE TEST RESULTS

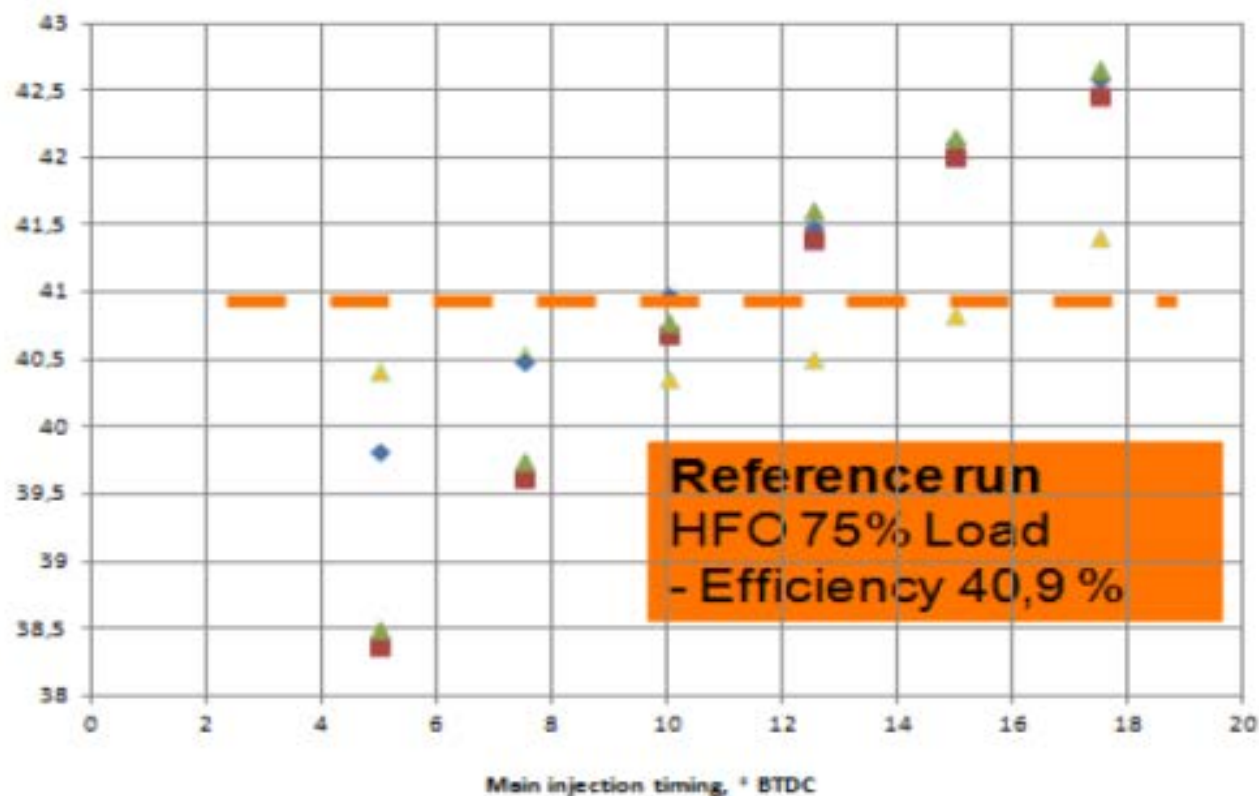

Same efficiency as diesel

Source: Wartsila, Promsus Workshop, Gothenberg, Sweden - May 6, 2014



Carbon Recycling International

PROMISING METHANOL SUPPLY OUTLOOK

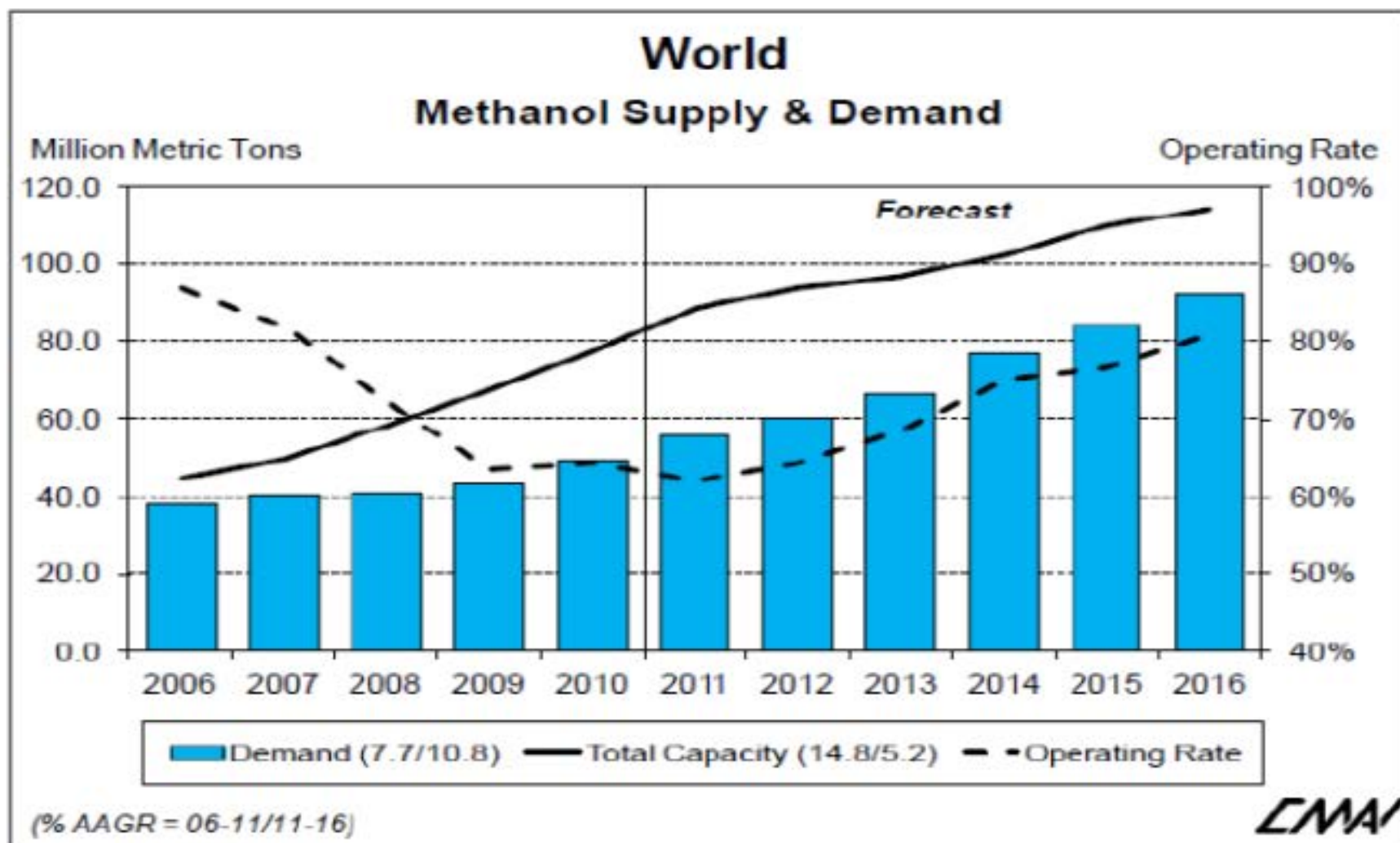

US Shale Gas: A Methanol Renaissance?

The shale gas powered resurgence of the methanol industry in the United States:

“If you add up all this activity we’re talking about getting to the point where the U.S. will have some 16 million metric tons of production capacity in the next three years. To put that in perspective, our current chemical demand is about 6.5 million metric tons so you could have an overhang of 10 million metric tons (3.3 billion gallons) looking for a market.”

Greg Dolan, Methanol Institute
July, 2014



Fuel comparison

(Based on conversion with 5 years pay-back and 6% interest)

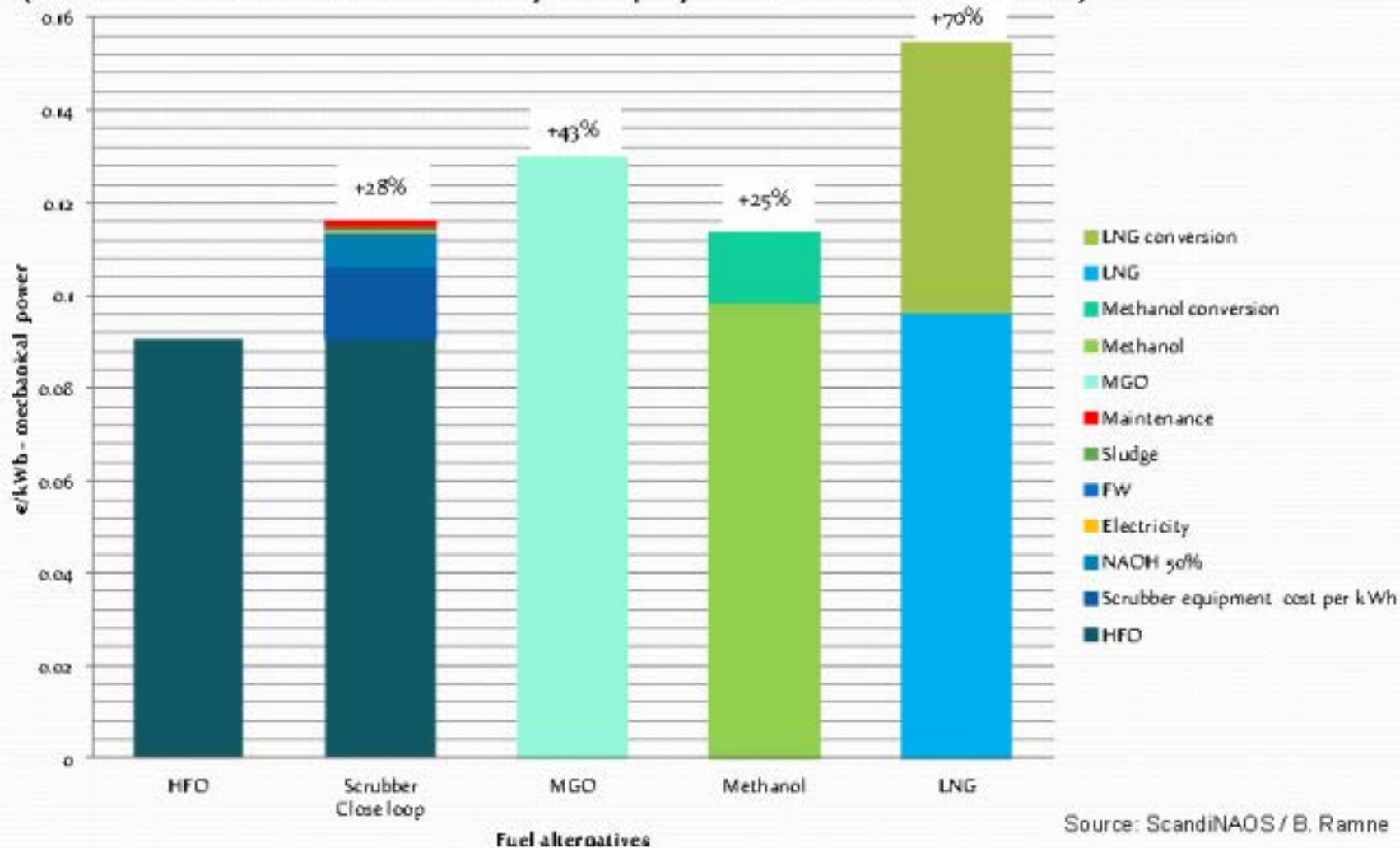

CONCLUSIONS:

- ▶ Methanol marine engines are maturing rapidly
- ▶ Methanol offers the lowest cost of compliance
- ▶ Sustainable methanol will continue to accelerate
- ▶ LNG infrastructure, in-use boil-off inefficiencies, and ship retrofit capital cost concerns pose far greater challenges than methanol fuels
- ▶ Methanol is available globally at reasonable and competitive prices
- ▶ The demonstration of methanol in EU marine applications will lead the way
- ▶ CA ports should incorporate methanol in their range of options for serious consideration



Takk Fyrir!



paul.wuebben@carbonrecycling.is



Carbon Recycling International

SUPPLEMENTAL SLIDES



Tests on Methanol - NOx (METHANOL-DIESEL)

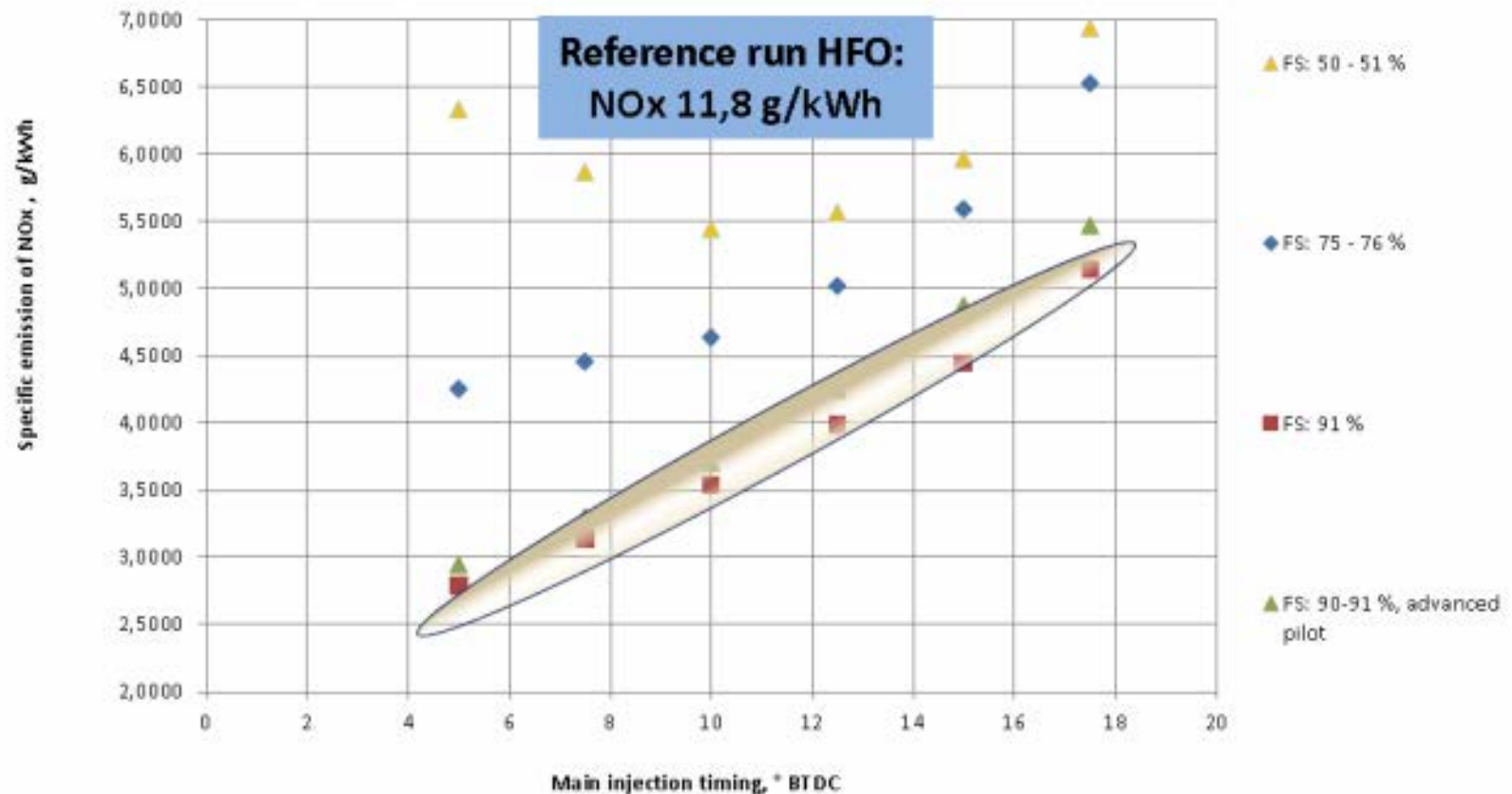

WARTSILA METHANOL-DIESEL TEST RESULTS:

Engine: 4L32LNGD

Output: 410kW/Cylinder

Compression ratio: 13.8:1

- NOx 3-5 g/kWh (Low Tier II)
- CO acceptable (< 1 g/kWh)
- THC acceptable (< 1 g/kWh)
- Very low PM (FSN ~ 0,1 with HFO as pilot)
- Formaldehyde emissions low ~ below TA-luft
- Efficiency comparable to running on diesel
- No Formic acid detected in exhaust gases



LNG Concerns:

The fact that LNG is stored at -260 degrees F and that its energy density is only 60 percent that of diesel fuel means there must be significant changes in a ship's engines, its tankage and fuel handing systems, and its overall design and operation.

- 1) **BOIL-OFF:** With cyrogenic fuels like LNG, there is a possibility for de - bunkering (or emptying the fuel tanks). This step is necessary when a ship is to be anchored for an extended period of time. Unless special LNG de - bunkering facilities are available in the port, the gas would boil off, causing huge methane losses to the atmosphere. In case of grounding accidents, a technique for de - bunkering would also be necessary.



LNG Concerns (cont.)

- 2) **PRESSURE INCREASES**: such increases are possible when consumption occurs below the natural boil-off rate, which will happen if there is no re-liquefaction plant available onboard. Re-liquefaction of boil-off gas requires about 0.8 kWh/kg gas. One large LNG carrier, such as Qatar Q-max, requires 5–6 MW of re-liquefaction power, corresponding to a boil-off rate of 8 tons/hour.
- 3) **METHANE SLIP**: inadvertent CH₄ emissions from larger marine engines burning NG can occur. Methane slip will be present, especially on four-stroke, dual-fuel NG engines, partly from the scavenging process in the cylinder and partly from the ventilation from the crank case, which is being led to the atmosphere.
- 4) **FUTURE RETROFIT REGULATIONS**: prohibitions may be placed on LNG tanks situated directly below accommodation which could cause difficulties in retrofitting certain ships.



Methanol may be permitted as a fuel onboard cargo ships

SOLAS II-2, Part B, Regulation 4.2.1 states...

4.2.1.1 except as otherwise permitted by this paragraph, no oil fuel with a flashpoint of less than 60° C shall be used,

4.2.1.4 in cargo ships the use of fuel having a lower flashpoint than otherwise specified in paragraph 2.1, for example crude oil, may be permitted provided that such fuel is not stored in any machinery space and subject to the approval by the Administration of the complete installation.



Carbon Recycling International

No Rules or Regulations specifically for use of methanol as a fuel onboard ships, but...

Rules for carriage of methanol

- *International Code for the Construction and Equipment of Ships Carrying Dangerous Chemicals in Bulk (IBC Code)* - IMO
- *Rules and Regulations for the Construction and Classification of Ships for the Carriage of Liquid Chemicals in Bulk* - Lloyd's Register

Rules for use of low flash point fuels

- *International Code for the Construction and Equipment of Ships Carrying Liquefied Gases in Bulk (IGC Code)* - IMO
- *Rules and Regulations for the Construction and Classification of Ships for the Carriage of Liquefied Gases in Bulk* - Lloyd's Register



EPA METHANOL ASSESSMENT:

- ▶ **Soil** - Biodegradation is the major route of removal of methanol from soils. Several species of Methylobacterium and Methylomonas isolated from soils are capable of utilizing methanol as a sole carbon source (CHEMFATE 1994).
- ▶ **Water** - **Most methanol is removed from water by biodegradation.** The degradation products of methane and carbon dioxide were detected from aqueous cultures of mixed bacteria isolated from sewage sludge (CHEMFATE 1994). Aerobic, Gram-negative bacteria (65 strains) isolated from seawater, sand, mud, and weeds of marine origin utilized methanol as a sole carbon source (CHEMFATE 1994). **Aquatic hydrolysis, oxidation, and photolysis are not significant fate processes for methanol** (HSDB 1994).
- ▶ **Biota** - **Bioaccumulation of methanol in aquatic organisms is not expected to be significant** based on an estimated bioconcentration factor of 0.2 (HSDB 1994).

